



20/38-40 Chapman Street GYMEA NSW

2 1 1

Refreshed and updated, this top floor apartment affords a relaxing lifestyle of privacy and convenience displaying sun filled and airy open plan living areas enhanced by a sunlit entertaining balcony. The ultimate in convenient living, walk to rail, village shops and caf?s.

- * Only 3 apartments located in the block within the complex
- * Updated modern kitchen with soft close draws and gas stove top
- * Master bedroom with built in wardrobes and generous 2nd bedroom
- * Freshly painted, new carpet and new light fittings throughout
- * Single lock up garage with stairwell access directly to garaging

Type : Apartment

View : <https://www.jreproperty.com.au/sale/nsw/sutherland/gymea/residential/apartment/7488883>



Trent Jeffree
02 9540 2222

[For full version visit the website](https://www.jreproperty.com.au)

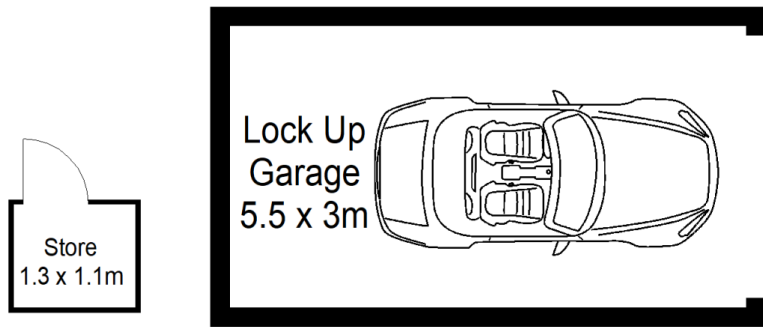

BASEMENT

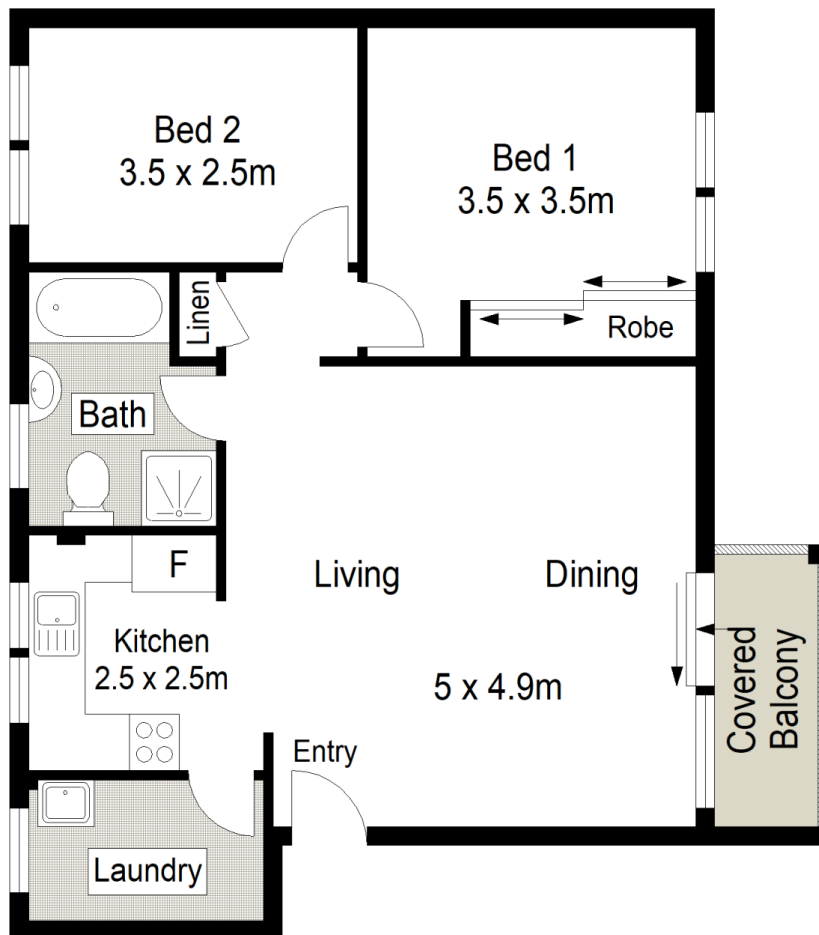

TOP FLOOR

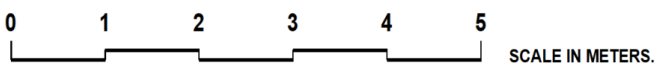

Scale in metres. Indicative only. Dimensions are approximate. All information contained herein is gathered from sources we believe to be reliable. However we cannot guarantee its accuracy and interested persons should rely on their own enquiries.

